

Flexible wood splitting

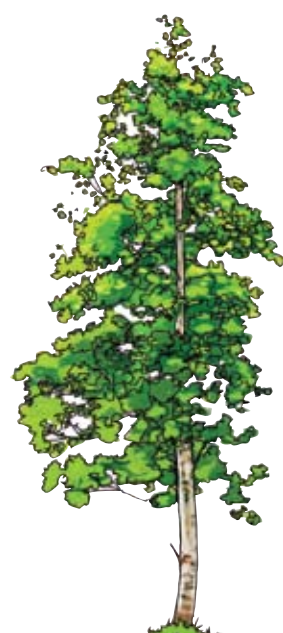



IX 37

The IX 37 is excellent for professional use but also offers a unique option for demanding domestic use or as a shared machine when making larger amounts of firewood. In the log splitter competition organised in the US in the spring of 2009, the IX 37 proved to be the fastest and most powerful machine in its category. Even though the machine only needs 7.5 kW of power and weighs just 600 kg, it can be used effectively to split trunks almost 40 cm thick. This exceptional power is best exhibited when making firewood out of trunks of varying sizes. The speed of the machine is automatically adjusted according to the size of the trunks.

Top-class production with Easy equipment

The IX 37 can be equipped with the Easy function to enhance its user-friendliness. With Easy equipment, wood can be moved forward or back and cut, and the height of the blade can be easily adjusted using hydraulic levers. This valuable Easy function eases work and improves productivity for professional users of the device.





Additional and optional equipment:

- Splitting blades for splitting into 2, 4 and 6 parts
- Log hoist: Woodlift 371
- Wood worktops: Woodran 371, 421 and 422
- Woodner cleansing drum

For technical specifications, please see back cover.

Hoists, worktops and drum

WOODLIFT 371 (39000)
WOODLIFT 371 (39000)
LENGTH: 2150 mm
WEIGHT: 70 kg
WIDTH: 1100 mm
HEIGHT: 50/850 mm
Machine: 2X 30 and IX 37

WOODLIFT 421 (63100)
LENGTH: 2150 mm
WEIGHT: c. 80 kg
WIDTH: 1150 mm
HEIGHT: 50/1000 mm
Machine: IX 42

WOODLIFT 472 (47900)
LENGTH: 2150 mm
WEIGHT: 100 kg
WIDTH: 1150 mm
HEIGHT: 50/1125 mm
Machine: BIGX 47

WOODRAN 471 (48500)
LENGTH: 3600 mm
WEIGHT: 616 kg
WIDTH: 960–1500 mm (adjustable)
HEIGHT: 1000–1440 mm (adjustable)
– 2 pincher rolls
– Adjustable legs
– Mechanical separator
– Optional extension 2–6 m
Machine: IX 42 and BIGX 47

WOODRAN 472 (47901)
LENGTH: 3500 mm
WEIGHT: 925 kg
WIDTH: 2200 mm
HEIGHT: 1000–1440 mm (adjustable)
– 3 pincher rolls
– Adjustable legs
– Mechanical separator
– Optional extension 2–6 m

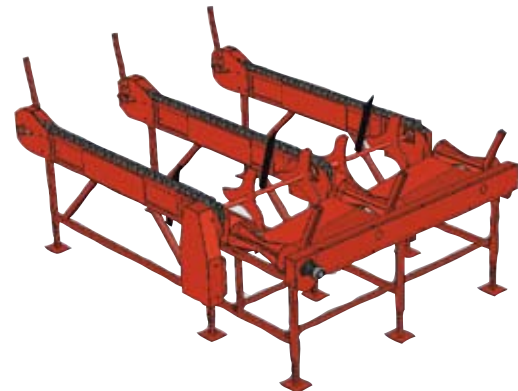

WOODRAN 371 (31052)
LENGTH: 2350 mm
WEIGHT: 200 kg
WIDTH: 2080 mm
HEIGHT: 880/1220 mm
Machine: 2X 30, IX 37 and OH 60

WOODRAN 421 (31200)
LENGTH: 2350 mm
WEIGHT: 238 kg
WIDTH: 2120 mm
HEIGHT: 880/1230 mm
– Hydraulic dispenser
– Adjustable legs
Machine: IX 37 and IX 42

WOODRAN 422 (31300)
LENGTH: 2480 mm
WEIGHT: 285 kg
WIDTH: 2280 mm
HEIGHT: (adjustable)
880–1,320 mm/1230–1660 mm
– Hydraulic dispenser
– Adjustable legs
– 2 pincher rolls
Machine: IX 37 and IX 42

WOODNER cleansing drum (62500)
LENGTH: 3300/2600 mm
WEIGHT: 630 kg
WIDTH: 1200 mm
HEIGHT:
3000–4000 mm
– Electric/hydraulic use
– Adjustable output strip
– Adjustable protecting flap
– Adjustable legs
Machine: All machines
except Eagle and Z100

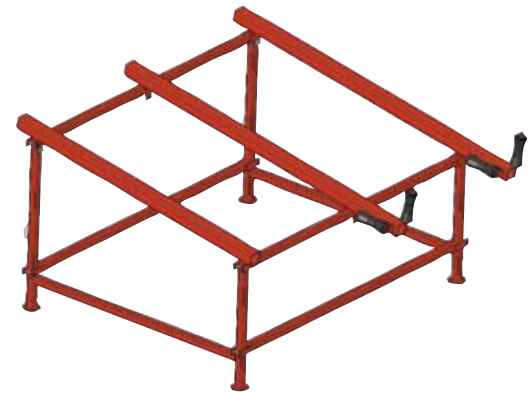

The Green X

The familiar X is now slightly green and proves the agility of the firewood machines and equipment, developed through long-term experience. The green X is also a mark of determined development work in renewable wood energy.

In addition to constantly striving to make our products more agile, we also want to develop as a flexible provider of products and services.

