



Staalmeester 

OPERATOR'S MANUAL
OPERATEURSHANDLEIDING

2021SP HAMMER MILL
HAMERMEUL

CONTENTS

DISCLAIMER	1
WARNING	
OPERATION INSTRUCTIONS	
REPLACEMENT OF THE SIEVE	2
THE ROTOR	
MISCELLANEOUS	5
TO REPLACE THE 4 HAMMERS	
TO REPLACE THE SIEVE	

INHOUD

VRYWARING
WAARSKUWING
BEDRYFSINSTRUKSIES
VERVANGING VAN DIE SIF
DIE ROTOR
ALLERLEI
OM DIE 4 HAMERS TE VERVANG
OM DIE SIF TE VERVANG

DISCLAIMER

The following is made in lieu of all warranties, express or implied; sellers and manufacturer's only obligation shall be to replace such product proved to be defective.

Neither seller nor manufacturer shall be liable for any injury, loss, or damage, direct or consequential, arising out of the use or the inability to use the product.

Before using, user shall determine the suitability of the product for his intended use, and user assumes all risk and liability whatsoever in connection therewith.

No statement or recommendation not contained herein shall have any force or effect unless an agreement signed by officers of seller and manufacturer.

Accepting delivery of the product, the user agrees to bind himself to the above.

WARNING

Personal injury may result if the following safety precautions are not observed:

- Do not operate the machine until the instruction manual has been read.
- Be sure the machine is connected to building electrical safety ground (earthed).
- Be sure power is off before performing machine maintenance or cleaning.
- Do not operate machine in a manner for which not intended.

OPERATION INSTRUCTIONS

The Staalmeester 2121 Hammer Mill is designed for milling and grinding of a variety of products, to almost any desired particle size, as determined by the selection of sieve. Incorporated into the design of the 2121, are several features, including a casing that will safely contain the rotating parts in the event of a catastrophic failure of the hammers or any other rotating parts.

MODERN HAMMER MILLS, such as the 2121 are very versatile milling machines, and may be used for a variety of milling and grinding applications.

The 2121 is designed for milling. Hammer mills contain parts that rotate at extremely high speed, and care must therefore be taken in the use and maintenance of such equipment. The product stream into the mill must be free of foreign bodies,

VRYWARING

Die volgende word gemaak in plaas van alle waarborge, uitdruklik of geïmpliseer; verkopers en vervaardigers se enigste verpligting is om sodanige produk te vervang as daar bewys kan word dat dit foutief is.

Nóg verkoper nóg vervaardiger sal aanspreeklik wees vir enige besering, verlies of skade, direk of gevolglik, wat voortspruit uit die gebruik of die onvermoë om die produk te gebruik.

Voor gebruik moet gebruiker die geskiktheid van die produk vir sy voorgenome gebruik bepaal, en gebruiker aanvaar alle risiko en aanspreeklikheid hoegenaamd in verband daarmee.

Geen verklaring of aanbeveling wat nie hierin vervat is nie, sal enige krag of effek hê tensy 'n ooreenkoms onderteken is deur beaamptes verteenwoordigend van verkoper en vervaardiger nie.

Deur die lewering van die produk te aanvaar, stem die gebruiker in om homself tot bogenoemde te bind.

WAARSKUWING

Persoonlike besering kan ontstaan as die volgende veiligheidsmaatreëls nie nagekom word nie:

- Moenie die masjien gebruik voordat die instruksiehandleiding gelees is nie.
- Maak seker die masjien is gekoppel aan die gebou se elektriese veiligheidsaarding.
- Maak seker dat krag af is voordat masjienonderhoud of skoonmaakwerk uitgevoer word.
- Moenie die masjien gebruik op 'n manier waarvoor dit nie bedoel is nie.

BEDRYFSINSTRUKSIES

Die Staalmeester 2121 Hamermeul is ontwerp vir die maal van 'n verskeidenheid produkte, tot byna enige verlangde deeltjiegrootte, soos bepaal deur die keuse van die sif. In die ontwerp van die 2121 is verskeie kenmerke ingesluit, insluitend 'n omhulsel wat die roterende dele veilig sal bewaar in die geval van 'n katastrofiese mislukking van die hamers of enige ander roterende dele.

MODERNE HAMERMEULENS, soos die 2121 is baie veelsydige maalmasjiene, en kan vir 'n verskeidenheid van maal- en slyptoeepassings gebruik word.

Die 2121 is ontwerp vir maalwerk. Hamermeulens beskik oor onderdele wat teen uiters hoë spoed roteer, en daarom moet sorg geneem word in die gebruik en instandhouding van sulke toerusting.

and is usually controlled by means of a flap, or similar device.

Again, great care must be taken to keep the incoming product stream free of foreign bodies. Only product free of contamination and known origin should be milled.

REPLACEMENT OF THE SIEVE

Milled product size is determined by size of sieve aperture used; a finer sieve will result in a finer product. The sieve is held in a basket assembly, which is clamped in position. Once the door is closed and secure with two wing nuts **NO ATTEMPT MUST BE MADE TO TRY AND OPERATE THE MILL WITH THE DOOR OPEN, THIS COULD LEAD TO SEVERE INJURY OR LOSS OF LIFE.**

Any sieve may be used, STAALMEESTER carries a wide variety of sizes in stock. The sieve is made in one part. It is held in place by a clamp with two bolts and nuts.

Only NYLOCK nuts are to be used to secure the sieve. The mounting nuts and the bolts must be checked for tightness periodically. The basket and sieve assembly are located on its mounting frame by means of positioning tabs, care must be taken to ensure the basket is fitted correctly between the tabs.

THE ROTOR

The double rotor consists of two blades and four hammers, hardened to forty-five Rockwell, to ensure safe operation and longevity.

Only hammers supplied by STAALMEESTER must be used, as these are supplied in matched sets, and are balanced before dispatch.

Hammers must always be replaced as a set, and new mounting nuts must be used every time. New mounting nuts are supplied with the hammers.

Under no circumstances must mild steel or other hammers be used, although the mill casing is designed to contain broken blades, severe damage will be caused to the machine, and costly repairs will be needed.

Service life of the hammers depends on actual operating conditions, and the hammers must be inspected after the first fifty operating hours, and every 100 hours thereafter. When the hammers become noticeably eroded, or become

Die produkstroom in die meule moet vry van vreemde voorwepe wees, en word gewoonlik deur middel van 'n flap of soortgelyke toestel beheer.

Weereens moet groot sorg geneem word om die inkomende produkstroom vry van vreemde voorwerpe te hou. Slegs produkte wat vry van kontaminasie is, en van bekende oorsprong is, moet gemaal word.

VERVANGING VAN DIE SIF

Gemaalde produk grootte word bepaal deur die grootte van die sif-opening wat gebruik word; 'n fyner sif sal 'n fyner produk tot gevolg hê. Die sif word in 'n mandjie-samestelling gehou wat in posisie vasgeklem word. Sodra die deur gesluit en beveilig is met twee vlerkmoere **MOET GEEN POGING GEMAAK WORD OM DIE MEUL MET DIE DEUR OOP TE PROBEER BEDRYF NIE, DIT KAN TOT ERGE BESERING OF LEWENSVERLIES LEI.**

Enige sif mag gebruik word, STAALMEESTER het 'n wye verskeidenheid groottes in voorraad. Die sif is in een deel gemaak. Dit word in plek gehou deur 'n klamp met twee boute en moere.

Slegs NYLOCK-moere moet gebruik word om die sif vas te maak. Die monteermoere en die boute moet gereeld nagegaan word vir styfheid. Die mandjie en sif-samestelling is op die monteerraam geplaas deur middel van posisioneringsoortjies, sorg moet gedra word om te verseker dat die mandjie korrek tussen die oortjies pas.

DIE ROTOR

Die dubbelrotor bestaan uit twee lemme en vier hamers, gehard tot vyf-en-veertig Rockwell, om veilige werking en lang lewe te verseker.

Slegs hamers wat deur STAALMEESTER verskaf word, moet gebruik word, aangesien dit in ooreenstemmende stelle verskaf word, en gebalanseer word voor versending.

Hamers moet altyd as 'n stel vervang word, en nuwe monteermoere moet elke keer gebruik word. Nuwe monteermoere word saam met die hamers voorsien.

Onder geen omstandighede mag sagte staal of ander hamers gebruik word nie, alhoewel die meulomhulsel ontwerp is om gebreekte lemme te vervat, sal ernstige skade aan die masjien aangerig word, en duur herstelwerk sal nodig wees.

Die dienslewe van die hamers hang af van werklike bedryfstoele, en die hamers moet na die eerste vyftig werksure, en elke 100 uur

unbalanced, they must be replaced as a complete set.

MISCELLANEOUS

The motor and bearing assemblies should be lubricated and requires regular maintenance. Spares and services are available from Staalmeester, or our designated agents. If in doubt, please do not hesitate to call. We are certain you will receive many years of trouble-free service from the Staalmeester 2121 Hammer Mill.

TO REPLACE THE 4 HAMMERS

- Loosen the three nuts (fig. 1.) and fit the new hammers. Hammers can also be turned around and be re-used.
- Remember to tighten the Nuts when re-fitted.



Fig. 1.

TO REPLACE SIEVE

- To replace the sieve, loosen the nuts and take out the lock-ring, take out the old sieve and replace with new (fig. 3.).
- Replace the sieve-ring and ensure nuts are securely tightened.

daarna, geïnspekteer word. Wanneer die hamers merkbaar geërodeer word, of ongebalanseer raak, moet hulle as 'n volledige stel vervang word.

ALLERLEI

Die motor- en laersamestellings moet gesmeer word, en vereis gereelde instandhouding. Onderdele en dienste is beskikbaar by Staalmeester, of ons aangewese agente. As jy twyfel, moet asseblief nie huiwer om ons te skakel nie. Ons is seker jy sal baie jare se probleemvrye diens van die Staalmeester 2121 Hamermeul geniet.

OM DIE 4 HAMERS TE VERVANG

- Maak die drie moere los (fig. 1.) en pas die nuwe hamers aan. Hamers kan ook omgedraai word en hergebruik word.
- Onthou om die moere vas te trek wanneer dit weer aangebring is.



Fig. 2.

OM SIF TE VERVANG

- Om sif te vervang, maak die moere los en haal die sluitring uit, haal die ou sif uit en vervang met nuwe (fig. 3.).
- Vervang die sifring en maak seker dat moere stewig vasgedraai is.

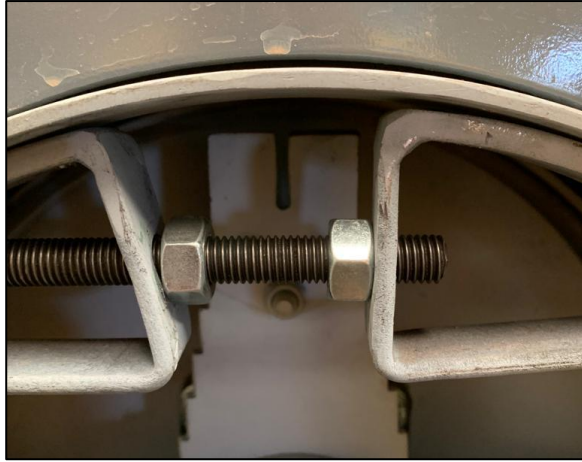
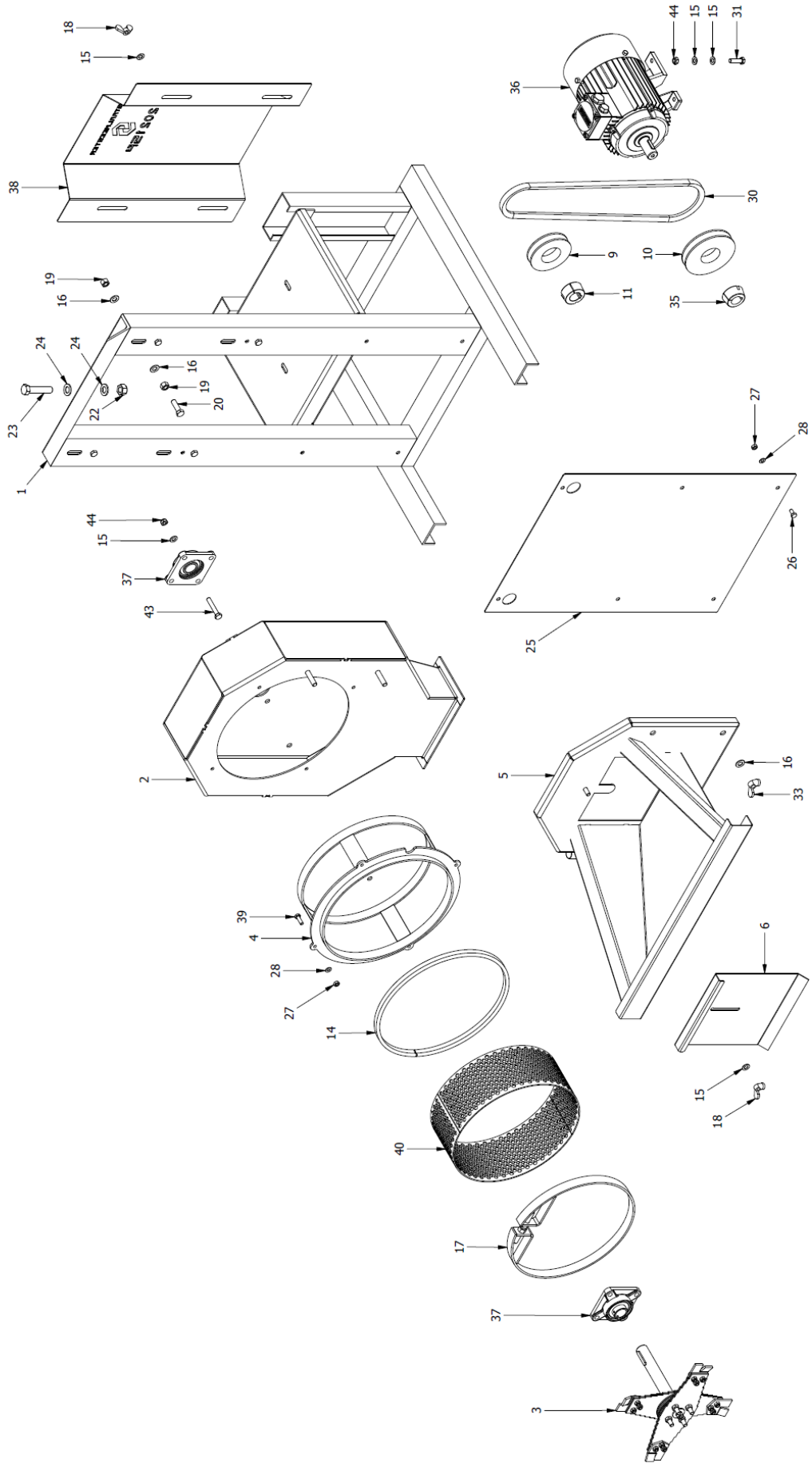

Fig. 3.

G0311 - 2021SP Hammermill



PARTS LIST				PARTS LIST			
ITEM	PART NUMBER	DESCRIPTION	QTY	ITEM	PART NUMBER	DESCRIPTION	QTY
1	H03010	Frame	1	23	M41675SET	Bolt M16x75 HT Galv	1
2	H03000	Box	1	24	M81602	Washer Flat M16x40x2	2
3	H03020	Rotor	1	25	M03063	Profile 2.0 MS PLB0	1
4	H03030	Rotor Cage	1	26	M40815	Bolt M8x16HT Galv	6
5	H03040	Inlet Chute	1	27	M31008	Nut M8 Galv	10
6	M03062	Profile 2.0 MS PLB3	1	28	M80803	Washer Flat M8 Galv	10
9	M5721	Pulley SPB 106-1V TL1610-30	1	30	M3835	Belt SPB-1340	1
10	M5722	Pulley SPB 132-1V TL1610-28	1	31	M41035	Bolt M10x35HT Galv	4
11	M5241	Taperlock bush 1610-30	1	33	M31201	Wing nut M12	2
14	R6185-0001	Rubber extrusion Pinchweld RS400	1	35	M5232	Taperlock bush 1610-28	1
15	M81002	Washer Flat M10 Galv	17	36	M03080	Motor 3kW 1-ph 2-pole	1
16	M81202	Washer Flat M12 Galv	10	37	M3301	Bearing UCF 206	2
17	H03050	Lockring	1	38	H03060	Profile 2.0 MS PLB2R	1
18	P911104	Wing nut M10	5	39	M40825	Bolt M8x25HT Galv	4
19	M31209	Nut M12 Galv	8	40	H03070	Sieve Ring G0311	1
20	M41240	Bolt M12x40 HT Galv	4	43	M11060	Bolt M10.0x60.0	4
22	M31612	Nut M16 Galv	1	44	M61007	Nut Nyloc M10 Galv	8

